

ENDS OF MAPS. III: DIMENSIONS 4 AND 5

FRANK QUINN

Topology in dimension 4 has recently been considerably illuminated by Freedman's embedding theorem for topological 2-handles, and even more recently by Donaldson's nonexistence theorem for smooth structures. This paper complements Donaldson's work, and extends Freedman's to the topological category, by proving (partial) existence and uniqueness theorems for smooth structures. The main theorems are actually 5-dimensional versions of the thin h -cobordism and end theorems proved in dimensions ≥ 6 in Ends of Maps, I [13]. These theorems are stated in §2.1, and proved in §3. They directly imply a number of useful facts about 4- and 5-manifolds, which we summarize:

In §2.2 we see that a homeomorphism of smooth 4-manifolds is isotopic to one which is smooth off a "standard singular set". Applying this to the special case of an open handle shows 0 and 1 handles can be straightened, and 2-handles can be straightened in several weak senses. (The 0-handle case is the classical "annulus conjecture".) This implies (via immersion theory) that the stability map $\text{TOP}(4)/O(4) \rightarrow \text{TOP}/O$ is 3-connected. In turn this implies that every 4-manifold has a smooth structure in the complement of a point, extending the canonical one on the boundary. In particular "almost smooth" can be deleted from the statement of Freedman's classification theorem [6, Theorem 1.5].

§2.3 demonstrates that topological 5-manifolds have handlebody structures, relative to arbitrary submanifolds of their boundary. This completes this problem: all topological manifold pairs $(M, \partial_0 M)$ have handlebody structures except nonsmoothable 4-manifolds.

In §2.4 most of the (few) remaining cases of topological transversality are settled. Map transversality holds without exception, but two cases of isotopy transversality of submanifolds remain undecided.

In §2.5 the homotopy characterization of local flatness is extended to dimension 4, except in codimension 2.

In §2.6 some of the general theory of cell-like maps is extended to dimension 4. The fact that a cell-like map of manifolds can be approximated by

homeomorphisms is now known in all dimensions (presuming local irreducibility in dimension 3). Similarly ANR homology manifolds of dimension 4 have resolutions. That extends this result to all dimensions except 3 (where it depends on the Poincaré conjecture).

Finally, in §2.7, some non- ϵ 5-dimensional h -cobordism theorems are proved. These include a proper h -cobordism theorem, and the fact that for certain $\pi_1 M$, some finite cover has a product structure. This implies in particular that a manifold homotopy equivalent to $D^j \times T^{4-j}$ ($T^n = n$ -torus) and with the same boundary, has a finite cover homeomorphic to $D^j \times T^{4-j}$.

A remark about the logical order of events may be helpful. The theorems are stated in their eventual proper generality. However in a number of cases the topological case of a theorem depends on application of the smooth version. Strictly, one should do the smooth case of the Thin h -Cobordism Theorem 2.1.1. Then proceed to the annulus conjecture and smooth structures (2.2), handlebody structures (2.3), and transversality (2.4). This establishes the basic ingredients of handlebody theory in the topological category. The constructions of §3 now work in a topological setting, so the same proof now establishes the topological version of the Thin h -Cobordism Theorem. After this continue, with the End Theorem 2.1.2, local flatness (2.5), cell-like maps (2.6) and topological h -cobordisms (2.7). Along the same lines we note that although the Cell-Like Approximation Theorem 2.6.2 is much stronger than Freedman's S^4 result [6, §9], it is logically dependent on that result.

2. Statements and applications

The thin h -cobordism theorem and the end theorem are stated in 2.1, and proved in §3. The applications are proved using these theorems.

2.1. Main theorems. Recall that an h -cobordism $(M; \partial_0 M, \partial_1 M)$ deformation retracts to both $\partial_0 M$ and $\partial_1 M$. If $M \rightarrow X$ is a proper map to a metric space, and $\delta > 0$, then $(M; \partial_0 M, \partial_1 M)$ is a δ , h -cobordism [13] if the deformations have diameter $< \delta$ in X . This means that the image of each arc $\{x\} \times I \subset M \times I \rightarrow M \rightarrow X$ has diameter $< \delta$ in X . The question is whether a (δ, h) -cobordism has a product structure with diameter $< \epsilon$.

A "fundamental group" condition is necessary here. A map $M \rightarrow X$ is $(\delta, 1)$ -connected if given a relative 2-complex (R, S) and a commutative diagram

$$\begin{array}{ccc} S & \longrightarrow & M \\ \downarrow \eta & \nearrow & \downarrow \\ R & \longrightarrow & X \end{array}$$

then there is a map $R \rightarrow M$ (the dotted arrow) such that the upper triangle commutes, and the lower one commutes within δ . (This is a little stronger than the condition used in Ends I, but renders the onto hypothesis unnecessary.)

2.1.1. Thin h -cobordism theorem. *Suppose X is a locally compact locally 1-connected metric space. Suppose $\epsilon: X \rightarrow (0, \infty)$. Then there exists $\delta: X \rightarrow (0, \infty)$ such that if $(M; \partial_0 M, \partial_1 M) \rightarrow X$ is a 5-dimensional $(\delta, 1)$ connected (δ, h) -cobordism then M has a topological product structure of diameter $< \epsilon$.*

This is the 5-dimensional version of Theorem 2.7 of Ends I, with $C = X$ and $D = \emptyset$. The analogous relative versions also hold (and will be used below).

Addendum. If M is smooth, then there is an ϵ product structure $\partial_0 M \times I \simeq M$ which is smooth off $U \times I$, where U is a "standard ϵ singular set". Topologically this is an ϵ topological regular neighborhood of a locally finite 1-complex. Smoothly it is contained in a smooth ϵ regular neighborhood of a locally finite smooth 2-complex $K \cup T$. K has $H^2(K; \mathbf{Z}) = 0$. T is a disjoint union of 5-stage towers, attached to K along circles in general position with respect to the intrinsic 1-skeleton K_1 , and which do not separate components of $K - K_1$. There is a framed immersed transverse sphere for each component of $K - K_1$ disjoint from the rest of $K \cup T$. Finally each tower, sphere, and component of $K - K_1$ has diameter $< \epsilon$.

This is rather complicated, but it will turn out we can push 2-complexes off such things by topological isotopy, and by smooth isotopy after small finger moves. (See the proof of 2.2.2.)

The smooth structure of the singular set is unlikely to be simplified much. It is possible that the topological structure may be improved to: a union of topological 4-balls. Note that if M is compact and 1-connected, then a 1-complex lies in a ball.

The next is the 5-dimensional analog of Ends I, Theorem 1.4. There are also relative and approximate versions corresponding to Ends I, 2.1 and 2.5. Refer to Ends I for terminology.

2.1.2. End theorem. *Suppose X is a locally compact locally 1-connected metric space. Suppose $e: M \rightarrow X$ has a tame 1-LC end, and $\dim(M) = 5$. Then a completion of $e: \partial M \rightarrow X$ extends to a topological completion of e .*

2.2. The annulus conjecture, and smoothings of 4-manifolds. We begin with our best approximation to the *hauptvermutung*.

2.2.1. Theorem. *Suppose $h: M \rightarrow N$ is a homeomorphism of smooth 4-manifolds, and $\epsilon: N \rightarrow (0, \infty)$. Then h is ϵ isotopic to a homeomorphism which is smooth except on an " ϵ semistandard" singular set. (See below for "semistandard".) This can be held fixed on a closed set with a neighborhood on which h is smooth.*

Suppose the mapping cylinder of h , denoted N_h , has a smooth structure extending the given one on $M \cup N \cup K_h$ where h is smooth on $h^{-1}(K) \rightarrow K$. Then projection $(N_h; M, N) \rightarrow N$ makes this a smooth $(\delta, 1)$ -connected, (δ, h) -cobordism over N , for all $\delta: N \rightarrow (0, \infty)$. The thin h -cobordism theorem (relative version, preserving the product structure given over K) would then apply to give small product structures. The homeomorphism $M \rightarrow N$ from this product structure is a close approximation to h , and is smooth off a standard singular set. If the approximation is close enough, local contractibility of the homeomorphism group [4] provides an isotopy to h . Therefore the theorem would follow from a smooth structure on N_h .

By a semistandard singular set we mean: an ϵ regular neighborhood of a smooth 1-manifold $S \subset M$, a function $\delta: M \rightarrow [0, 1)$ such that $\delta^{-1}(0) = S$ and $\delta < \epsilon$, and a δ standard singular set in $M - S$. (We have made no attempt to beautify this.) If there were a smooth structure on the mapping cylinder of $h: M - S \rightarrow N - h(S)$ we could get a δ approximation to this with δ standard singular set. But the choice of δ ensures that a δ approximation would extend to an ϵ approximation on all of M , by defining it to be h on $S \rightarrow h(S)$. This gives semistandard singularities.

Finally we find S . Since N_h is 5-dimensional, the extension problem is a map $(N_h, M \cup N) \rightarrow B_{\text{Top}/O}$ [9]. Since $N_h \simeq M \times I$ this is the suspension of a map $M \rightarrow \text{Top}/O \simeq S^3 \cup_2 D^4 \cup$ (higher cells). Deform into $S^3 \cup_2 D^4$ and make transverse to the circle $\{\text{pt}\} \cup [-1, 1]$. The inverse image serves as S , since the obstruction is trivial on the complement.

This completes the proof of 2.2.1. Applied to the special case of an open handle we get

2.2.2. Handle straightening (Generalized annulus conjecture). *Suppose $h: D^j \times \mathbf{R}^{4-j} \rightarrow W$ is a homeomorphism of smooth manifolds, smooth on the boundary. If $j = 0$ or 1 then h is isotopic rel boundary and a neighborhood of the end to a map which is smooth on a neighborhood of $D^j \times \{0\}$. This is generally false if $j = 2$, but there is an isotopy to a map smooth on a set V , which can be taken to be either a neighborhood of $D^2 \times \{0\}$ after some finger moves to introduce self-intersections, or the image of a neighborhood of $D^2 \times \{0\}$ under a topological ambient isotopy (rel ∂ and ∞).*

We note the unfortunate possibility, unlike higher dimensions, that a topological ambient isotopy can change the smooth structure. (Concordance does not imply isotopy.) A little more information about 2-handles is given in 2.2.4.

The original form of the annulus conjecture was: suppose $f: S^n \rightarrow D^{n+1}$ is a topologically locally flat embedding. Then the region between S^n and $f(S^n)$ is homeomorphic to $S^n \times I$ (an annulus). The case $n = 0$ of the theorem implies

this if $n = 3$: M. Brown showed [1] that f extends to an embedding $D^{n+1} \rightarrow D^{n+1}$, the theorem provides an ambient isotopy of a neighborhood which makes this smooth, in which case the result is well known (and easy). This is now known in all dimensions, the higher-dimensional cases being the key step in the Kirby-Siebenmann theory [8], [9].

Proof of 2.2.2. Apply 2.2.1, holding a neighborhood of the boundary (where h is smooth) fixed. We use the local contractibility of homeomorphisms [4] to see that we can hold a neighborhood of the end fixed also. Now in the cases $j = 0$ or 1 there is a smooth ambient isotopy of $D^j \times \{0\}$ off the singular set. If $j = 2$ since it is topologically 1-dimensional there is a topological isotopy of $D^2 \times \{0\}$ off. It remains only to see that there is a differentiable isotopy off after finger moves.

Let $K \cup T$ be the core of the smooth description of the singular set, and put D^2 in general position. Intersections with the towers T can be pushed down into the manifold part of K . We arrange the algebraic intersection of D^2 with each component of $K - K_1$ to be algebraically zero: since $H^2(K, \mathbf{Z}) = 0$ the algebraic intersections come from a cochain on K_1 . This can be realized as intersections by pushing pieces of D^2 across arcs in the 1-skeleton. So far we have changed D^2 only by smooth isotopy.

Choose smoothly immersed Whitney discs for the intersections $D^2 \cap K$. Since the attaching circles of the towers do not separate components of $K - K_1$, the Whitney arcs in K can be chosen to lie in the manifold part. Push the Whitney discs off the towers T through K , and use the transverse spheres to the components of $K - K_1$ to get discs disjoint from K . Finally make the discs disjointly embedded by pushing intersections off through D^2 . They are disjoint from $K \cup T$ now, but may intersect D^2 . Remove intersections with D^2 by pushing D^2 off through itself. These are the finger moves of the theorem. Finally use the Whitney discs to push D^2 off K . The image of the D^2 with finger moves is now disjoint from the singular set of the homeomorphism.

The reason the theorem is false for $j = 2$ without finger moves comes from Donaldson's theorem [2]. Consider the Kummer surface, which has quadratic form $E_8 \oplus E_8 \oplus 3\begin{bmatrix} 0 & 1 \\ 1 & 0 \end{bmatrix}$. Since there is no smooth manifold with form $2E_8$, it is impossible to find 3 smoothly embedded 2-spheres representing the $3\begin{bmatrix} 0 & 1 \\ 1 & 0 \end{bmatrix}$ summands (otherwise do surgery). Freedman [6, Theorem 1.9] has constructed smooth immersions, together with topologically embedded Whitney 2-handles ($D^2 \times R^2$) which can be used to make the spheres topologically embedded. If all of the topological 2-handles, considered as smooth manifold homeomorphic to $D^2 \times R^2$, contained smooth 2-handles, then we would obtain the forbidden smooth embeddings.

This completes the proof of 2.2.2. Immersion theory [7], [12], [11], [9] interprets the handle result as a calculation of homotopy groups of classifying spaces. Therefore we immediately obtain

2.2.3. Corollary. *The map $\text{TOP}(4)/O(4) \rightarrow \text{TOP}/O$ is 3-connected. Consequently any 4-manifold has a smooth structure in the complement of a point, extending the canonical structure on the boundary.*

Freedman's embedding theorem, and the central nature of the Whitney trick, makes clear the importance of smooth structures on $D^2 \times R^2$. The main theorem of Freedman [6] is that a Casson handle is homeomorphic to $D^2 \times R^2$. The next proposition relates the general case to this class of examples. For this we define an embedding $j: D^2 \times (\text{int } D^2) \rightarrow D^2 \times R^2$ which is the identity on the boundary to be *weakly unknotted* if there is a (topological) ambient isotopy of the standard $D^2 \times (\text{int } D^2)$ rel boundary and a neighborhood of the end, into the image of j .

2.2.4. Proposition. *Every smooth structure on $D^2 \times R^2$ smoothly contains a weakly unknotted Casson handle. Any Casson handle has a smooth weakly unknotted embedding in the standard structure.*

All of these are understood to be standard on the boundary, $(\partial D^2) \times (\text{int } D^2)$. Note that putting the two clauses together gives: there is a topological ambient isotopy rel boundary of $D^2 \times R^2$, so that the image of $D^2 \times (\text{int } D^2)$ has a strange smooth structure.

Proof of 2.2.4. In each case we construct a Casson handle in the standard $D^2 \times R^2$ by: begin with $D^2 \times \{0\}$. Do finger moves to introduce intersections. These have standard embedded discs spanning the kinks. Do finger moves on the cores of these inside regular neighborhoods of the discs. Repeat infinitely. In the first case the finger moves are necessary to avoid the singularities of a homeomorphism $D^2 \times R^2 \rightarrow W$ given by 2.2.1. In the second case we are realizing some preassigned pattern (this is an essential step in Freedman's proof).

The unknottedness comes from an observation of R. Edwards that we can undo the finger moves on the core, inside the Casson handle and obtain a disc isotopic to the original core. This depends on a double unknotting lemma of Casson and Gordon. However it is easy to see if the Casson handle is built with Whitney and accessory discs, as in [15]. A finger move comes with a canonical Whitney disc which undoes it. Later stages of the construction give a 5-stage tower inside a regular neighborhood of this disc, so by Freedman an embedded Whitney disc. This smaller Whitney disc also undoes the finger move, and gives an isotopic image of $D^2 \times \{0\}$ inside the handle.

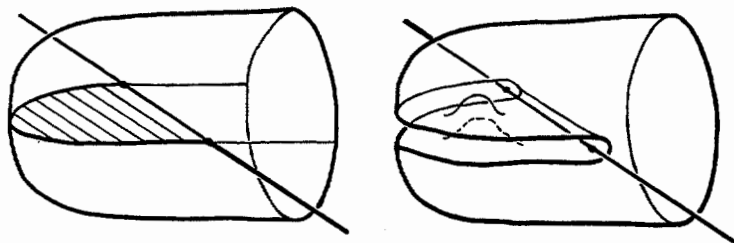

2.3. Handlebody structures on 5-manifolds. Suppose M is a manifold, $\partial_0 M$ a codimension 0 submanifold of ∂M . A handlebody structure on $(M, \partial_0 M)$ is a description of M as built up by attaching layers of handles to the top of a collar $\partial_0 M \times I$. There were shown to exist if $\dim(M) \geq 6$ by Kirby and Siebenmann [9]. The *hauptvermutung* for 3-manifolds shows that a 4-manifold has such a structure if and only if it is smoothable. The next theorem settles the remaining case.

2.3.1. Theorem. *Any 5-manifold pair $(M, \partial_0 M)$ has a (topological) handlebody structure.*

Proof. It is sufficient to consider the compact case. Also suppose $\partial_0 M$ and $\partial_1 M (= \partial M - \text{int } \partial_0 M)$ are nonempty; delete a ball (= 0 or 5-handle) if not. The obstruction to finding a vector bundle structure on the stable tangent bundle is a map to $B_{\text{TOP/O}}$. As in the proof of 2.2.1 this is trivial on the complement of a locally flat 1-manifold. By pushing pieces of this to the boundary we can assume it consists of finitely many flat arcs from $(\text{int } \partial_0 M)$ to $(\text{int } \partial_1 M)$. Delete these, and at least one arc ending on each component of $\partial_0 M$ and $\partial_1 M$. Denote the result by $(M^1, \partial_0 M^1, \partial_1 M^1)$. Then each component of $\partial_i M^1$ is open. By the Stability Theorem 2.2.3 there is a $0(4)$ structure on the unstable tangent bundle, and by immersion theory a corresponding smooth structure extending the canonical one given on $\partial(\partial_i M^1)$. Since the bundle structure extends to M^1 , again immersion theory extends the smooth structure to all of M^1 .

The ends of $M^1, \partial_0 M^1$ are topologically collared as $[0, \infty) \times S^3 \times I$, so are (δ, h) -cobordisms over $[1, \infty) \subset [0, \infty)$ for any $\delta > 0$. (Or alternatively proper h -cobordisms satisfying Freedman [6, 1.12] or 2.6.1 below.) The proof of the h -cobordism theorem asserts that a handlebody structure on $M^1, \partial M^1$ (which is smooth) sufficiently small near the ends, can be manipulated so that the handles near the ends cancel (topologically). This leaves a finite handlebody structure on $(M^1, \partial_0 M^1)$. Replacing the arcs gives a finite handlebody structure, on a manifold easily seen to be homeomorphic to M .

2.4. Topological transversality. Map transversality concerns a map $f: M \rightarrow X$ with M a manifold and X containing a microbundle. The assertion is that f is

homotopic to a map transverse to the microbundle. Submanifold transversality concerns locally flat submanifolds $P, Q \subset M$, and asserts that one is ambient isotopic to a submanifold transverse to the other.

2.4.1. Theorem. *Map transversality holds in all dimensions. Submanifold transversality holds except possibly in ambient dimension 4 with one submanifold of dimension 3 and the other ≥ 2 (i.e. dimension of intersection ≥ 1).*

Proof. The cases excluded by Kirby and Siebenmann [9, essay 111] are those with ambient dimension 4, preimage dimension 4, or one submanifold of dimension 4 and the other of codimension 1. The preimage dimension 4 cases follow from Freedman's theorem [6, Corollary 1.4], via Scharlemann [17]. The ambient dimension 4 map theorem and submanifold of dimension 4 follow from the almost smoothability of 4-manifolds (2.2.3).

Submanifolds of a 4-manifold remain. Working locally, we may assume the one of larger dimension, say P , is a smooth submanifold of a smooth 4-manifold. If the other, Q , has dimension 0 or 1 then the Handle Straightening Theorem 2.2.1 provides an isotopy to a smooth submanifold, which can then be made transverse. The case remaining is Q of dimension 2.

By the handle straightening theorem, the nonsmooth surface is isotopic to a smooth one, Q' , after some finger moves which introduce self-intersections. Each finger move comes with a topological Whitney disc. As in the proof of 2.2.4 we can find a smooth 5-stage tower inside a neighborhood of this disc. Now by smooth isotopy we can make Q' with its towers transverse to P . Then push intersections with the towers off through Q' . Finally undo the finger moves in Q' with a Freedman disc inside the towers. This gives a surface topologically isotopic to Q (see 2.2.4), and transverse to P .

We remark here that $N^2 \subseteq M^4$ is the only dimension in which locally flat codimension 2 submanifolds are not known to have normal bundles [10].

2.5. Local flatness. The homotopy criteria for local flatness extend to dimension 4, except for codimension 2.

2.5.1. Theorem. *Suppose $N^p \subseteq \text{int}(M^4)$, with $p = 0, 1, \text{ or } 3$. Then N is locally flat in M if and only if it is 1-LC embedded.*

Considerably stronger (but more complicated) statements are true. In particular Theorem 3.4.1 of Ends I is now known for M^n , $n \geq 4$, except for codimension 2 in $n = 4$. Note that the manifold factor hypothesis is redundant [16]. In codimension 1, Theorem 3.4.2 of Ends I is now known for dimensions ≥ 4 . The proof given here gives a sharpened version of Lemma 4.3 of Ends I, from which these things follow.

Proof. According to the higher-dimensional characterization, $N \times R$ is locally flat in $M \times R$. By restricting to an open set in N if necessary, we may assume that $N \times R$ is flat: there is a homeomorphism on a neighborhood

$\theta: (N \times R) \times R^j \rightarrow M \times R$. Choose t large enough so that $M \times \{0\}$ and $\theta(N \times \{t\} \times B^j)$ are disjoint. Define $W = \theta(N \times (-\infty, t] \times B^j) \cap M \times [0, \infty)$, and define $p: W \rightarrow N \times [0, \infty)$ by projecting $N \times R \times R^j$ to N , and the radius in the R^j coordinate. Note that $N \times [0, t] = p^{-1}(N \times \{0\})$.

We claim that by modifying the $[0, \infty)$ coordinate by an automorphism, the map $p: W - N \times [0, t] \rightarrow N \times (0, \infty)$ can be made a (δ, h) -cobordism over $N \times (0, 1)$ for any $\delta: N \times (0, \infty) \rightarrow (0, \infty)$.

The theorem follows from this claim: let $\epsilon: N \times (0, \infty) \rightarrow (0, \infty)$ be projection on the second coordinate. Then by 2.1.1 there is a δ so that a $(\delta, 1)$ -connected (δ, h) -cobordism over $N \times (0, 1)$ has an ϵ product structure. The claim gives a (δ, h) -cobordism, which is $(\delta, 1)$ -connected if j (the codimension of N) is not 2. The choice of ϵ ensures that the homeomorphism between the ends of this h -cobordism extends continuously by the identity on N to give a homeomorphism of a neighborhood of $N \subset N \times \{t\} \times R^j$ with a neighborhood of $N \subset M \times \{0\}$. Therefore N is locally flat in M .

We verify the claim. There is a deformation retraction of $M \times [0, \infty)$ to $M \times \{0\}$ which is standard on $N \times [0, \infty)$ and preserves its complement. This restricts in particular to give a deformation of W in $M \times [0, \infty)$. Next there is a deformation retraction of $N \times R \times R^j$ to $N \times (-\infty, t] \times R^j$, standard on $N \times R$ and preserving its complement. Use this second retraction on the image $\theta(N \times R \times R^j)$ to push the image of the first retraction (on some neighborhood of $N \times [0, t]$) into W . This gives a deformation of a neighborhood of $N \times [0, t]$ in W to $M \times \{0\}$, standard on $N \times [0, t]$ and preserving its complement. On $W - N \times [0, t]$ this gives a proper deformation retraction of some neighborhood of the end over $N \times \{0\}$ into one boundary component. This retraction satisfies δ estimates in the N coordinate for sufficiently small r in the $(0, \infty)$ coordinate, because it extends to W by the standard deformation of $N \times [0, t]$ to $N \times \{0\}$. Properness can be used to obtain δ estimates in the $(0, \infty)$ coordinate after reparameterization, as in the proof of 2.7.1.

This gives a δ -deformation retraction of (a neighborhood of the end of) $W - N \times [0, t]$ to one boundary. A deformation to the other boundary is obtained similarly, giving it the structure of a (δ, h) -cobordism.

2.6. Cell-like maps. The next result extends the resolution theorem of [16] to dimension 4.

2.6.1. Theorem. *Suppose $(X, \partial X)$ is a 4-dimensional ANR homology manifold, with ∂X a manifold. Then there is a cell-like map (resolution) $M \rightarrow X$ with M a manifold, which is a homeomorphism on the boundary. Any two such are boundaries of a resolution of $X \times I$, so in particular are ϵ homeomorphic for any $\epsilon > 0$.*

This is now known in every dimension except 3, where it depends on the Poincaré conjecture. We note Edwards' shrinking theorem [3] has no 4-dimensional analog yet, so we do not have a characterization of manifolds in that dimension.

The following corollary (of uniqueness, with X a manifold) fills the gap between theorems of Armentrout ($\dim = 3$) and Siebenmann ($\dim \geq 5$), so is known in all dimensions. (Assuming no fake cells in dimension 3.)

2.6.2. Corollary. *A cell-like map between 4-manifolds can be approximated by homeomorphisms.*

Proof of 2.6.1. According to [16], $X \times \mathbf{R}$ has a resolution, $N \rightarrow X \times \mathbf{R}$ which is a homeomorphism on the boundary. The End Theorem 2.1.2 (rel boundary version) applies to one end of the composition $N \rightarrow X$. The boundary of the resulting completion is a resolution (cf. Ends I, 3.2.2). Given two resolutions $f: M \rightarrow X$, $f': M' \rightarrow X$, we get a cell-like map of the double mapping cylinder $X_f \cup X_{f'} \rightarrow X \times I$. Apply [16] to resolve the double mapping cylinder, then the composition to $X \times I$ gives the uniqueness statement. The Thin h -cobordism Theorem 2.1.1 gives ϵ product structures (over X) on resolutions of $X \times I$.

2.7. 5-dimensional h -cobordisms. The objective is to use the thin h -cobordism theorem to obtain results which do not involve ϵ .

2.7.1. Proper h -cobordism theorem (weak version). *Suppose $(M; \partial_0 M, \partial_1 M)$ is a 5-dimensional proper h -cobordism with finitely many 1-connected ends. Then there is a topological product structure in a neighborhood of the ends. If M itself is 1-connected, then M is a product.*

Notice that Freedman's version [6, Theorem 10.4] is not restricted to finitely many ends. For example it applies to proper h -cobordisms of the universal cover of $(S^1 \times S^3) \# (S^1 \times S^3)$.

Proof. There is a proper map to a 1-point union of half-open intervals $\bigvee^n [0, \infty)$ which takes each end to an interval. Since the h -cobordism has proper deformation retractions, we can describe its size in terms of closed intervals in $[0, \infty)$. Then by composing with a compression toward 0 we can convert this into a δ estimate, any $\delta > 0$. It can therefore be made a (δ, h) -cobordism over $\bigvee^n [0, \infty)$. Similarly if the ends are 1-connected we can make it $(\delta, 1)$ -connected off of $\bigvee^n [0, 1]$, and if M is also 1-connected we can make it $(\delta, 1)$ -connected over all of $\bigvee^n [0, \infty)$. Then apply the Thin h -Cobordism Theorem 2.1.1.

2.7.2. Proposition. *Suppose $(M, \partial_0 M, \partial_1 M)$ is a compact 5-dimensional h -cobordism such that $\pi_1 M$ has a free abelian group of finite index. Then some finite cover of M has a product structure.*

It may be possible to extend this to poly- (finite or cyclic) groups (i.e., finite index poly \mathbf{Z}) by using the methods of [5].

Proof. We show that for every $\delta > 0$ there is a finite cover $\hat{M} \rightarrow T^n$ which is a $(\delta, 1)$ -connected (δ, h) -cobordism over T^n . The Thin h -Cobordism Theorem 2.1.1 will then apply.

Suppose (after finite cover if necessary) that $f: M \rightarrow T^n$ induces isomorphism on π_1 . Choose deformations of M to $\partial_0 M, \partial_1 M$. Then in the universal cover $\tilde{f}: \tilde{M} \rightarrow \tilde{T}^n = \mathbf{R}^n$ these have some bounded diameter b , as measured in \mathbf{R}^n . Let k be so large that $k\delta > b$. Then

$$\tilde{M}/k\mathbf{Z}^n \xrightarrow{\tilde{f}} \mathbf{R}^n/k\mathbf{Z}^n \xrightarrow{1/k} \mathbf{R}^n/\mathbf{Z}^n = T^n$$

has deformations of diameter $< \delta$.

There is a similar argument for $(\delta, 1)$ -connectedness: let S be the 1-skeleton of M and R the mapping cylinder of S to the 2-skeleton of T^n . Since f is an isomorphism on π_1 , the inclusion $S \subset M$ extends to a map $R \rightarrow M$. On the universal cover there is some bounded distance between the inclusion $\tilde{R} \subset \mathbf{R}^n$ and the composition $\tilde{R} \rightarrow \tilde{M} \rightarrow \mathbf{R}^n$. Pass to a cover as above to get skeleta and distance $< \delta$. Any relative 2-complex δ -deforms into this one, so has a δ lift.

2.7.3. Corollary. *Suppose $f: W \rightarrow D^j \times T^{4-j}$ is a homotopy equivalence which is a homeomorphism on the boundary. Then some finite cover of f is homotopic rel boundary to a homeomorphism.*

Proof. It follows from 5-dimensional surgery that there is an h -cobordism from W to $D^j \times T^{4-j}$.

3. Proof of the main theorems

The key to the proof is the Disc Deployment Lemma 3.2, which disjointly embeds an infinite number of discs with ϵ control. Essentially this is all that is missing from the high-dimensional proof. The deployment lemma follows from careful use of the pushing operation described in 3.1. This is built up of standard operations. See [14] for simple descriptions and applications of these operations.

These constructions are valid (up until the application of Freedman's theorem) in both the differentiable and topological settings. However, as remarked in the introduction, the topological case uses basic facts about discs (approximation by immersion, transversality) which require the smooth case in their proof.

3.1. Pushing over a transverse sphere. The data is: M is a 4-manifold with immersed surfaces C_1, C_2 , and framed immersed spheres C_1^t, C_2^t . These are all

in general position and have intersections $q_i \in C_i \cap C_i^t$, $p \in C_1 \cap C_2$ (and possibly others). In applications C_i^t will usually be a transverse sphere (i.e. $C_i \cap C_i^t = q_i$), but we do not require this here. We picture this with half of these surfaces drawn 1-dimensional, so that the intersections can be drawn correctly.

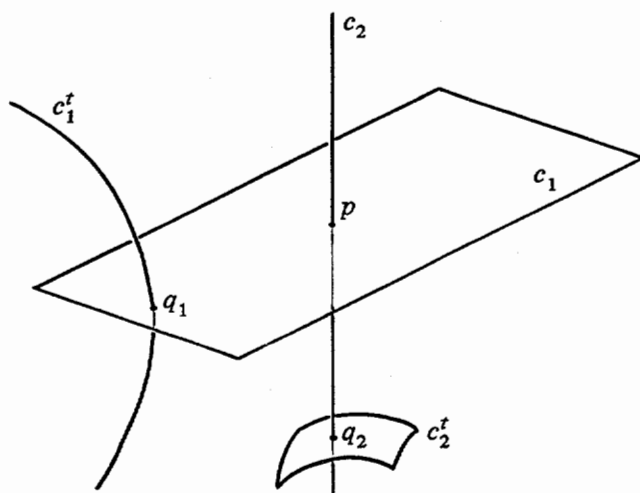

Next there is a disc D attached to $C_1 \cup C_2$ by an arc which changes sheets at p (usually a Whitney disc), and a surface E which intersects D . This completes the data. The objective is to move E off of D .

Choose arcs a_1, a_2 in C_i from p to q_i , and an arc b from the intersection $E \cap D$ to C_1 .

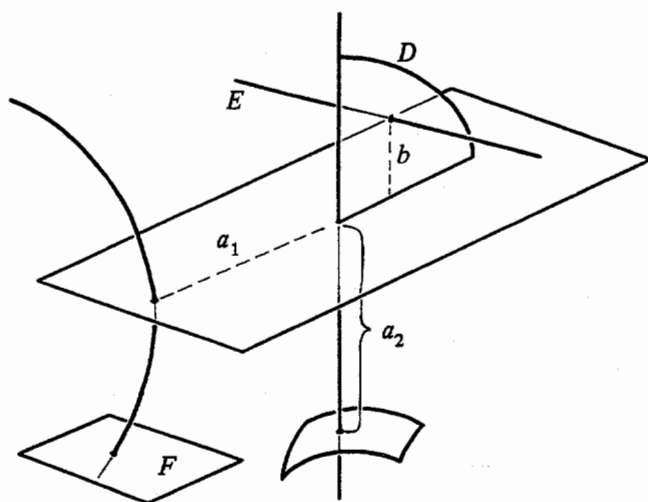

Modify E as follows: near the intersection point $E \cap D$ push E along the arc b , off D . This introduces new intersection points with C_1 . Remove these by connected sums with parallel copies of C_1^i , along arcs parallel to b_1 in C_1 . Call the result E' .

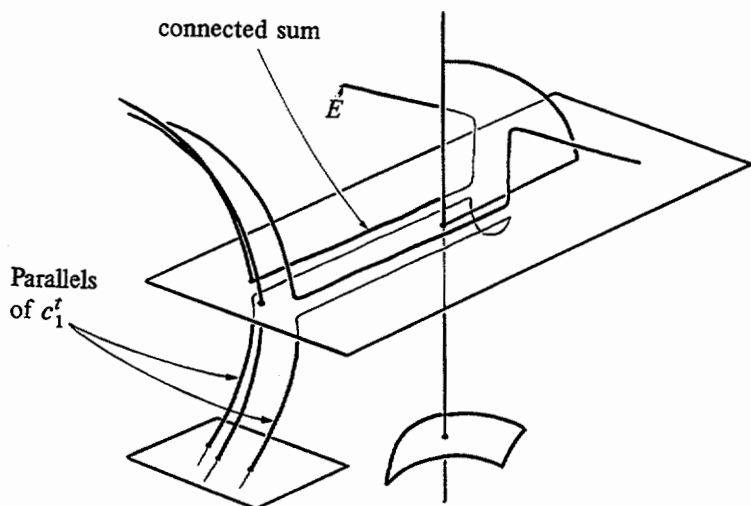

We say that E' is obtained from E by pushing to C_1 and over C_1^i . As suggested by the terminology there is a canonical regular homotopy from E to E' . We will not use it, so will not display it.

The important properties of E' are:

- (1) *New intersections of E' with any surface result from intersections with $C_1^i - p_1$.*
- (2) *These intersections occur in pairs, with Whitney discs. The Whitney discs intersect only surfaces which intersect $C_2^i - p_2$.*
- (3) *E' and these Whitney discs lie in a regular neighborhood of the data given.*

These Whitney discs are constructed as follows: let C_1^i intersect a surface F , and choose an arc from $F \cap C_1^i$ to p_1 . There is a ribbon lying between the copies of this arc on the copies of C_1^i used in the connected sum. This continues by a ribbon between the parallel tubes used in the connected sum. The result is a Whitney disc for the intersections $E' \cap F$ which satisfies all the conditions, except for an intersection point with C_2 just below p . Finally take a connected sum of this Whitney disc with C_2^i along the arc a_2 .

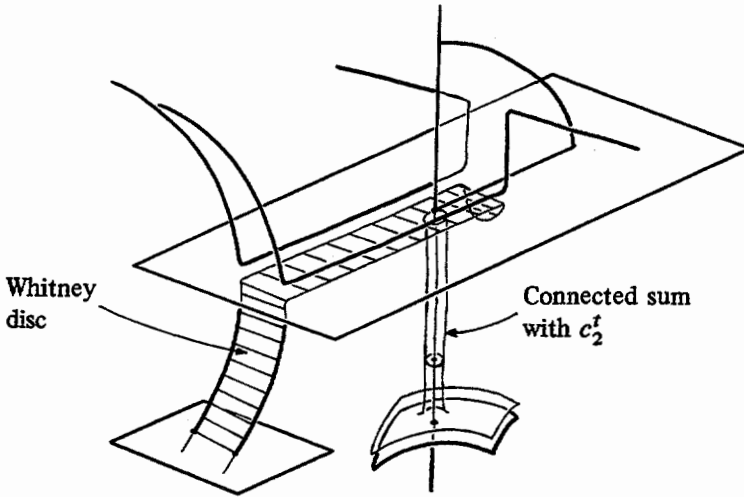

In most applications of this operation we will want to change E' further, to make it disjoint from some of these F which intersect $C_1' - p_1$. We cannot immediately push E' across the Whitney disc supplied in (2). Usually it will intersect some G (which intersects $C_2' - p_2$), and we want $E' \cap G = \emptyset$. What we will be able to arrange is that intersections are allowed between F and G . Therefore after pushing G off the Whitney disc through F , we can use it to separate E' and F .

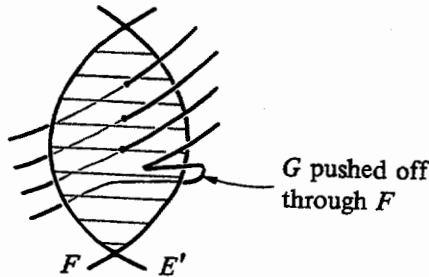

The end result is that at the expense of finger moves (Casson moves) of G through F , we can separate E from D, G, F . We will repeat this argument in each application, to specify what the F, G are.

3.2. The disc deployment lemma. *Suppose X is a locally compact, locally 1-connected, metric space. Then given $\epsilon > 0$ there exists a $\delta > 0$ (ϵ, δ are functions, $X \rightarrow (0, \infty)$ if X is not compact) such that: given the data*

(1) $f: N^4 \rightarrow X$ proper, $(\delta, 1)$ -connected.

(2) $C_\alpha, \partial C_\alpha \rightarrow N, \partial N$ are immersed 2-discs with disjoint boundary circles, are locally finite, and have algebraic intersections $C_\alpha \cdot C_\beta = 0$.

- (3) $C_\alpha^t \rightarrow N$ is a set of framed immersed transverse spheres for the C_α , and
- (4) C_α, C_α^t have images in X of diameter $< \delta$,

then there exists a collection of disjoint 5-stage towers $T_\alpha \rightarrow M$ bounding the curves ∂C_α with the same framings, with images in X of diameter $< \epsilon$, and smooth if M is smooth.

We will usually use Freedman's theorem to embed discs in all these towers. Recall that transverse spheres for a collection intersect the whole collection in the single points $C_\alpha \cap C_\alpha^t$.

Proof. We will show that in the situation of 3.2 we can make the C_α disjoint from each other. We then build 5-stage towers by embedding single layers 5 times.

The C_α are separated in two steps. First they are separated into groups. The number of operations required, hence the size estimate, depends on the numbers of groups which can intersect. Since we will be able to choose δ after the number is known, we can control the size of this step directly.

Next the discs inside a group are separated from each other. The number of operations required for this cannot be estimated. However, we will build enough data into each "group" so that these operations can be done in a regular neighborhood of the group. The final size estimate comes from the size of (components of) the groups.

The first step is to construct Whitney discs for the intersections $C_\alpha \cap C_\beta$, $\alpha \neq \beta$. Since algebraically $C_\alpha \cdot C_\beta = 0$ the intersections can be arranged in pairs with Whitney circles. These circles have images of diameter $< 2\delta$ in X . Since X is locally 1-connected, if δ is small enough the circles extend to maps of discs of diameter $< \gamma$, for any preassigned $\gamma > 0$. Then since $N \rightarrow X$ is $(\delta, 1)$ -connected these lift within δ to discs in N .

Call these discs D_* . We change them to be Whitney discs disjoint from C_* and C_*^t , and to have zero algebraic intersections.

Spin about arcs on ∂D_* to correct the framing, if necessary. This makes them Whitney. Take connected sum with the C_*^t to make disjoint from C . Then correct the algebraic intersections. This can be done by pushing some intersections among the D_* to C_* and over C_*^t (operation 3.1). The new intersections are algebraically zero, since they even have Whitney discs. These operations involve connected sum of D_a with C_a^t , only if $C_\alpha \cap D_b \neq \emptyset$ and $D_b \cap D_a \neq \emptyset$ for some b . Therefore the result has diameter $< 3\gamma + 4\delta$.

It remains to make the D_* disjoint from C_*^t . At every intersection point push C_*^t to C_* and over C_*^t . The resulting $(C_*^t)'$ also intersect the D_* , but only in new intersections with Whitney discs. The Whitney discs intersect $(C_*^t)'$ and D since the C^t do. Push the intersections of D_* off across D_* . Then push $(C_*^t)'$ across the Whitney discs. The D_* have been changed by finger moves, and are

disjoint from $(C_*^i)'$. Again these moves involve only adjacent discs and spheres, so have limited diameter ($< 12\delta$).

Group separation. Suppose we have the data of 3.2, and also the Whitney discs constructed above, all of diameter $< \delta$. Suppose the C_* are assigned to n groups $C_{1,*}, \dots, C_{n,*}$. Then they can be modified to satisfy the previous hypotheses, except now diameter $< 12^n\delta$, and for $i \neq j$, $C_{i,*} \cap C_{j,*} = \emptyset$. Furthermore this modification can be done in a regular neighborhood of the data given.

We actually separate the Whitney discs, then push across them. Let $D_{i,*}$ denote the Whitney discs for intersections between discs in $C_{i,*}$ and $C_{j,*}$, $j > i$. Let $D_{[j,n],*}$ denote $\bigcup_{i=j}^n D_{i,*}$.

At all intersections of $D_{1,*}$ with $D_{[2,n],*}$ push $D_{[2,n],*}$ to C_* and over C_*^i . Since $C_*^i \cap D_* = \emptyset$ this gives separate $D_{1,*}$ and $D'_{[2,n],*}$. It introduces intersections $D_{[2,n],*} \cap C_*^i$ in pairs with Whitney discs. The Whitney discs may intersect $D'_{[2,n],*}$ and C_*^i . Push C_*^i off through C_*^i , and push $D'_{[2,n],*}$ across the disc.

This separates $D_{1,*}$ and $D_{[2,n],*}$, reproduces the other data, and increases diameter by a factor of 12 or so.

Repeat the process to separate $D_{2,*}$ from $D_{[3,n],*}$. Since the $D_{[3,n],*}$ are already disjoint from $D_{1,*}$, and the separation takes place in a neighborhood of $D_{[2,n],*} \cup C_*^i \cup (C_* - D_{1,*})$, it does not create new intersections with $D_{1,*}$. After n steps, the D_* are separated as desired, and have diameter $< 12^n\delta$.

Next use these Whitney discs to move C_* . Push $C_{1,*}$ across the $D_{1,*}$. This may introduce intersections among the $C_{1,*}$, but they become disjoint from $C_{j,*}$, $j > 1$, and stay disjoint from C_*^i and $D_{j,*}$, $j > 1$. Repeat to separate all $C_{j,*}$.

This proves the statement of "group separation". However, we have to separate more data for each group before we try to separate within groups.

Suppose the $C_{j,*}$ are separated as above. Choose small Whitney discs $D_{j,*}$ for each group, and separate them by the same argument. Do this a third time: choose Whitney discs $E_{j,*}$ for the intersections of $D_{j,*}$, and separate them. The final data we require is transverse spheres $D_{j,*}^i$ which are also separated. Note the D, E are disjoint from C_*^i .

Construct $D_{1,*}^i$ by beginning with small 2-spheres which intersect $D_{1,*}$ in exactly two points. Push one point to C_* and over C_*^i . Aside from the remaining point $D_{1,*}^i \cap D_{1,*}$ these intersect only C_*^i and other $D_{1,*}^i$. These intersections occur in pairs with Whitney discs, which also intersect only C_*^i and $D_{1,*}^i$. Separate $D_{1,*}^i$ from C_*^i as usual: push C_*^i off the Whitney disc through C_*^i , and then push $D_{1,*}^i$ across the disc. Repeat to construct spheres

$D_{2,*}^f$. Since the construction takes place in a neighborhood of $C_{*,*}^f$ which are disjoint from $D_{1,*}^f$, $D_{2,*}^f$ is disjoint from $D_{1,*}^f$. Continue, to obtain $D_{j,*}^f$.

We now have the following statement: given n, ϵ , there is δ so that if we begin with discs C_* of diameter $< \delta$ and assign them to n groups, we can separate the following for these groups: the $C_{i,*}$, Whitney discs for these ($D_{i,*}$), Whitney discs for these ($E_{i,*}$), and transverse spheres $D_{i,*}^f$. Finally all of these have diameter $< \epsilon$.

With this we can complete the argument, except for the choice of the groups. Fix j . A regular neighborhood of $D_{j,*} \cup E_{j,*} \cup D_{j,*}^f$ satisfies the hypotheses of the group separation statement, forgetting about ϵ, δ and letting each $D_{j,\alpha}$ be a group. The conclusion is that we can separate the $D_{j,\alpha}$ completely, inside this regular neighborhood. Since the groups i, j have disjoint neighborhoods, we can separate all the D_* completely. Push across them to separate the C_* completely.

Finally we explain how to choose the groups. In the last step all we know about the separated $D_{j,*}$ is that they lie in a regular neighborhood of the data $D_{j,*} \cup E_{j,*} \cup D_{j,*}^f$. We arrange this regular neighborhood to have small components.

Suppose ϵ is the eventual size goal. Cover X by open sets with compact closure, and diameter $< \epsilon$. Choose a locally finite subcover. From this we get a cover $\{Y_i\}$ such that each component of \bar{Y}_i has diameter $< \epsilon$. (Y_1 is a maximal subset of the locally finite cover whose elements are disjoint. Y_2 is a maximal subset of the remainder, and so on.) If K is a (large) compact set in X , it will intersect finitely many of the Y_i , say n . Then there is $\gamma > 0$ so that for each i if the components of Y_i which intersect K are enlarged by adding points with γ , they will still be disjoint. Now let δ be small enough to separate n groups of discs and end up with size $< \gamma$.

If we start with data in 3.2 of size less than this δ , and assign discs to groups depending on which Y_i their image intersects, we will be able to separate them completely, over K . Such δ over various K can be pieced together to give $\delta: X \rightarrow (0, \infty)$ which works over all of X . (This piecing is not absolutely trivial, however.)

This completes the disjoint deployment of single discs. As indicated at the beginning of the proof, the tower statement follows by applying this repeatedly.

3.3. Proof of the thin h -cobordism theorem 2.1.1. Again we remark that since the first step is to choose a handlebody structure, we must have the smooth version and therefore 2.3 before we can even start the topological case.

The proof given in Ends I, 6.3 is valid up to the last paragraph of page 313. This reduces to 2- and 3-handles with 2-spheres correctly paired algebraically

in the middle level. Next the handles can be moved by isotopies so that the union of both collections of spheres has (framed immersed) transverse spheres. This is essentially Lemma 10.1 of Freedman [6], and can easily be done with ϵ control. Then framed immersed Whitney discs can be found as in the proof of the deployment lemma, disjoint from the spheres and transverse sphere. The deployment lemma itself replaces these by disjoint towers. Applying Freedman's embedding theorem we obtain disjoint embedded topological Whitney discs. Now the high-dimensional proof resumes, cancelling the handles and leaving a product structure.

We justify the addendum. The only nonsmoothness comes from the last Whitney push, across discs from Freedman's theorem. The product structure is therefore smooth off a smooth regular neighborhood of the image in $\partial_0 M$ of the attaching sphere of the 3-handles, and the 5-stage towers. Transverse spheres come from those for the attaching spheres, and the cohomology statement follows from the properties of the intersection form. This gives the smooth addendum.

For the topological addendum, note the structure is smooth off a topological regular neighborhood of the image of the attaching spheres, union the discs embedded in the 5-stage towers. The image in $\partial_0 M$ of the ascending spheres of the 2-handle is the linking circle. So the image of attaching spheres for 3-handles is a sphere with punctures, and boundaries of the punctures identified to these circles. Whitney discs close off loops between sheets.

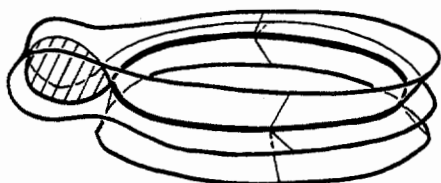

Such a thing has the same regular neighborhood as a surface with fewer punctures and an arc to the circle.

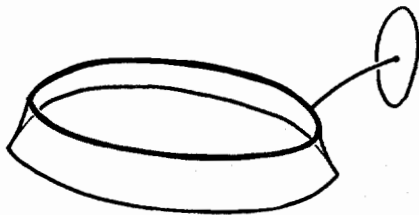

Do this with all Whitney discs and we are left with embedded discs (which collapse to points) and various arcs. This proves the topological addendum to 2.1.

3.4. Proof of the end theorem 2.1.2. As with the h -cobordism theorem the only missing ingredient is the disc deployment lemma. This is required to construct (topological) approximate completions, in the fourth paragraph on page 320 of Ends I. Note that transverse spheres are supplied. This and the topological thin h -cobordism theorem imply the end theorem (Ends I, 2.8).

This concludes the proof.

References

- [1] M. Brown, *A proof of the generalized Schoenflies theorem*, Bull. Amer. Math. Soc. **66** (1970) 74–76.
- [2] S. Donaldson, to appear in this journal.
- [3] R. D. Edwards, *Approximating certain cell-like maps by homeomorphisms*, preprint 1977.
- [4] R. D. Edwards & R. Kirby, *Deformation of spaces of embeddings*, Ann. of Math. **93** (1971) 63–88.
- [5] F. J. Farrell & W.-C. Hsiang, *The Whitehead group of poly- (finite or cyclic) groups*, J. London Math. Soc. (2) **24** (1981) 308–324.
- [6] M. Freedman, *The topology of four-dimensional manifolds*, J. Differential Geometry **17** (1982) 357–453.
- [7] A. Haefliger & V. Poenaru, *Classification des immersions*, Inst. Hautes Études Sci. Publ. Math. **23** (1964) 75–91.
- [8] R. C. Kirby, *Stable homeomorphism and the annulus conjecture*, Ann. of Math. **89** (1969) 575–582.
- [9] R. C. Kirby & L. Siebenmann, *Foundational essays on topological manifolds, smoothings, and triangulations*, Annals of Math. Studies, no. 88, Princeton Univ. Press, Princeton, 1977.
- [10] ———, *Normal bundles for codimension 2 locally flat embeddings*, Proc. Top. Conf. Park City Utah, Lecture Notes in Math. Vol. 438, Springer, Berlin, 1975.
- [11] R. Lashof, *The immersion approach to triangulation and smoothing*, Proc. Adv. Study Inst. Alg. Topology, Aarhus, 1970, 282–355.
- [12] J. A. Lees, *Immersions and surgeries of topological manifolds*, Bull. Amer. Math. Soc. **75** (1969) 529–534.
- [13] F. Quinn, *Ends of maps I*, Ann. of Math. **110** (1979) 275–331.
- [14] ———, *The stable topology of 4-manifolds*, Topology Appl., to appear.
- [15] ———, *Freedman's embedding theorem for towers*, preprint, 1982.
- [16] ———, *Resolutions of homology manifolds and the topological characterization of manifolds*, preprint, 1982.
- [17] M. Scharlemann, *Transversality theories at dimension 4*, Invent. Math. **33** (1976) 1–14.

VIRGINIA POLYTECHNIC INSTITUTE AND STATE UNIVERSITY